



**PROVEN CUTTING
TECHNOLOGIES
FOR PETFOOD PRODUCTION**



Your perfect partner for precision cutting of all ingredients for petfood applications

FAM STUMABO delivers cutting solutions for diverse food applications, backed by over 40 years of experience and a global reach.

We have been the trusted partner for **start-up companies** and **leading petfood processors** worldwide.

At FAM STUMABO you will find an experienced and innovative partner with an **open-minded approach**.

Our cutting technology provides peak production capacity of quality products with the highest level of efficiency. **It is designed to dice, strip cut or shred frozen, chilled or hot cooked organ meats, poultry, and fish products to a wide range of sizes.**

"Together we cut your product to perfection!"

INNOVATIVE SOLUTIONS FOR PETFOOD

The petfood industry requires constant variety and options to cater to the diverse needs of pets and their owners. This variety encompasses different formulations, ingredients, textures, and **shapes** to accommodate dietary requirements, health concerns, and lifestyle choices.

FAM STUMABO developed a range of cutting machines **for consistent slicing, dicing, and shredding (hand-pulled look)** a variety of products to achieve the best possible shape, appearance and cut quality.

FAST, HIGH VOLUME PROCESSING & MAXIMUM VERSATILITY

Whether you are producing diced organ meat, freeze-dried blends or fresh frozen applications — **our machines deliver clean, consistent cuts tailored to your product and packaging needs.** From finely diced pieces for slurry-style wet food to larger frozen chunks for freeze-drying, **we help turn your raw materials into premium petfood.**



PRODUCE KNOWLEDGE

Our robust machines are designed for fast, high-volume processing and offer **maximum versatility** to process beef, lamb, pork, poultry, fish in cooked (chilled and hot), frozen, dry, and/or extruded (hot) conditions.

Typical applications include organ meats (such as frozen liver, lung, and heart), fish (frozen cod, salmon, white fish, and tuna loin), chicken (such as logs, rolls, ribs, and end-cuts), extruded products, protein slabs, jerky-type treats, and others.

Our Food R&D team researches the different applications and studies the parameters such as the **shape, temperature, product, size, texture, moisture, salt, fat content** and the **condition** of the product. Only then can we select the best cutting solution, delivering the greatest value and best result for the customer.

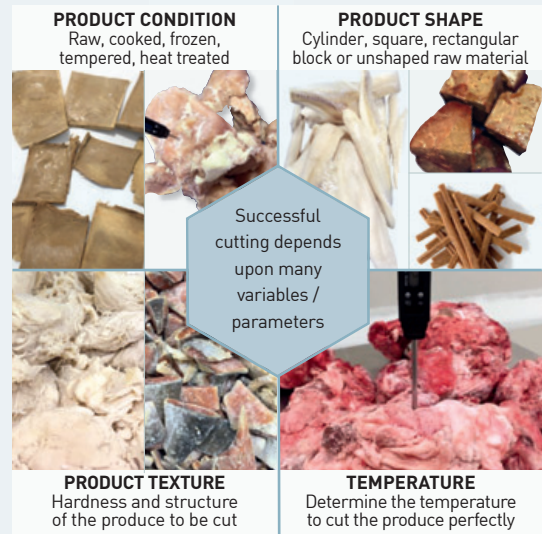

PRODUCTION PROCESS KNOWLEDGE

FAM STUMABO designs machines, blades and cutting tools that respond to your unique processing needs. Tailored not just to your current production line, but to offer that added flexibility. This allows you to **easily integrate our machinery** into any full line with quick and effortless switching of the cutting equipment. We **offer infeed and outfeed systems appropriate for specific applications** on our machines.

CMD.2 with integrated Exit Conveyor facilitates discharging the products into totes, Eurobin trolleys or additional conveyor systems.

MACHINE DESIGN KNOWLEDGE

All **blades** are **manufactured in-house** and made from the best food grade stainless steel materials.

Our expertise helps to select the right blade for the application.

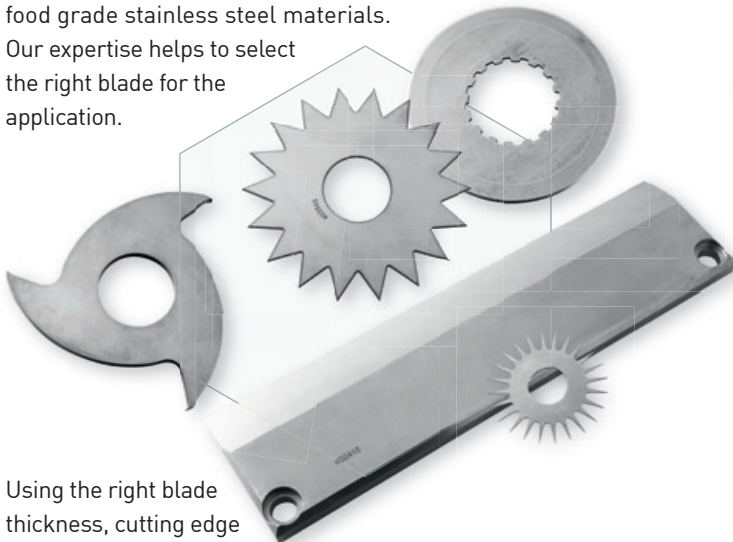

Using the right blade thickness, cutting edge grind, edge profile and strength is critical for the best cutting process with minimum waste.

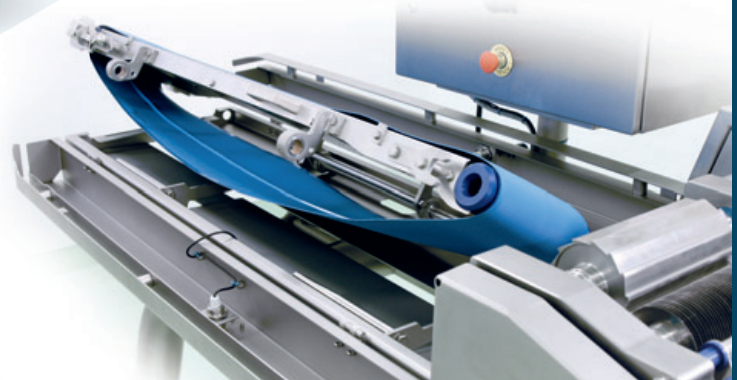

Hygienic focus: All equipment is designed to meet the highest food safety standards and will support our customers in the production of safe petfood. It permits also fast, yet thorough cleaning.

Our machines are designed for flexible and effortless operation with a special focus on ensuring the **safety of operators and maintenance personnel at every risk level**. The cutting tools ensure a long service life under all conditions, with minimal maintenance costs and downtime, through their **simplified yet rugged construction**.

State-of-the-art cutting solutions for petfood



Machines for high-qu

Hymaks



Uncompromising sanitary design for high-capacity outputs

- Robust, highest capacity large drum dicer with a unique and uncompromising sanitary design.
- Striking power potential of 20,5 kW (27,5 HP) with two synchronised motors with variable frequency drives. One of 5,5 kW (7,5 HP) for the cutting tools and one of 15 kW (20 HP) for the impeller.
- Highly uniform dicing and strip-cutting of cooked and tempered-frozen meat products and extruded meat substitute products with a minimum of waste.
- An HMI touchscreen helps the operators easily adjust slice thicknesses, operating speeds and safe recipes.

Results of high-quality dicing



Freeze-dried organ meat dice



Extruded meat dice

Quality strip-cutting and dicing

CMD₂



Continuous operation for high capacities

- Robust, high-capacity drum dicer capable of uniform cutting of frozen liver, lungs and hearts in very clean dice and strips.
- Powerful 11 kW (15 HP) motor with variable frequency drive can handle extreme conditions.
- Ability to cut at very low temperatures between 2 °C and -15 °C (35,6 °F and 5 °F), depending on texture, fat, moisture and salt content. Resulting in a non-sticky, free rolling product, simplifying the weighing and packaging.
- Superior, attractive cut quality as the product is not forced through a cutting grid but gently cut with rotating knife spindles.
- Removable splined shafts that make it quick and easy to switch cutting tools.

Flexifam₂



Designed for flexible and effortless operation

- Medium high-capacity dicing and strip-cutting for cooked and tempered-frozen meat products.
- 7 HP (5,5 kW) motor with optional variable frequency drive
- Produces very clean dice and shreds in sizes ranging from very small to medium.
- Unique disassembly and reassembly system for the cutting spindles enables fast changeover from one cut size to another in just minutes.
- The hinged infeed and discharge chute facilitates access to the machine and enables thorough cleaning.
- The hinged control cabinet provides quick access to the drive compartment for maintenance and repair interventions.



Fresh frozen dice

Accurate and versatile

Yuran
Hytec 300



Results of high-quality pulled look and chunks



Pulled chicken coarse



Pulled chicken fine



Extruded meat chunks

Increased feeding capacity and unrivalled cutting versatility

- Belt-fed dicer designed to dice, strip-cut and shred a large variety of meat and protein products.
- Compared to the standard model Yuran Hytec 240, the 300 mm wide feed belt offers an increased capacity and the ability to process products with larger dimensions.
- Multi-product cutting versatility due to the use of dual independent variable speed motors. Dice, strips, pulled look shreds, chunks can be produced from products of a pre-determined or natural thickness with a minimum of cutting tools.
- Specialized cutting tools, designed to cope with the unique characteristics of extruded products.
- Quick removable splined shafts of the cutting spindles provide fast changeovers from one cut size to another reducing downtime in the production process.
- Smart hygienic design ensures that the machine can be cleaned quickly, easily and safely.
- The **Yuran™ Hytec 300 EC** integrates an Exit Conveyor and brings several advantages specifically for batch processing. The exit conveyor helps effectively capture the cut pieces and eliminates product loss or spillage.

Yuran
Hytec 300 EC



belt cutters

Flexis
Optitec



Technically advanced flat-belt slicer for maximum flexibility

- Ultra-flexible flat-belt slicer designed for slicing preformed slabs and flat sticks at low to medium capacity.
- Cut quality is enhanced by a top-driven belt providing an optimal grip on the product before it is delivered to the knives.
- Simple, hygienic construction, including quickly detachable belts, makes the machine easy to clean and disinfect.
- Quick, efficient changeover of cutting tools and cut sizes flexibility by changing the speed of the feed belt and knives.

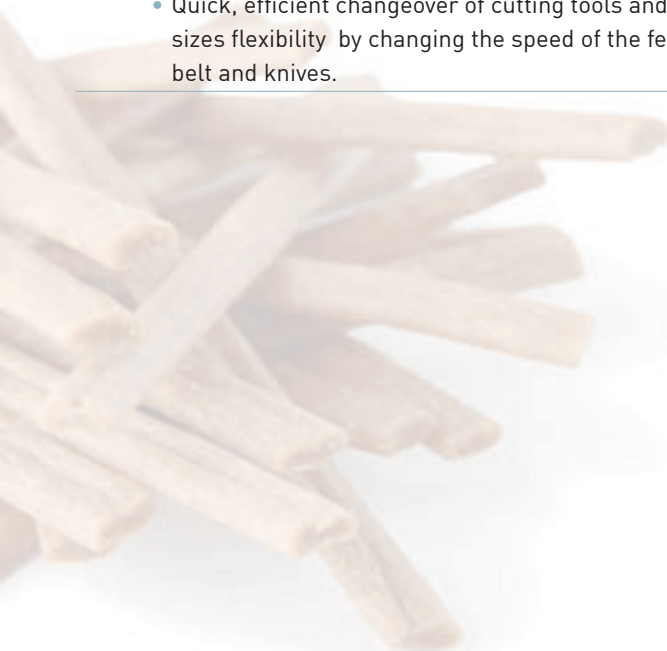

Precise V-belt slicer

Volantis



V-belt slicer designed for precision transverse slicing of a wide variety of elongated products

- Precise cutting of elongated and flat products from 25 mm (1") up to a diameter of 60 mm (2 3/8") such as dried treats, sticks, jerky treats.
- Perfect product enclosure and guidance towards the cutting tools by means of the driven top belt.
- Two-meter-long V-belt will perfectly align the product towards the slicing wheel and bring it up to the required speed before cutting.
- Product is sliced without waste or end pieces.
- Transversal cutting principle allows precise high-speed slicing while maintaining an excellent slicing quality.
- Highly efficient machine design resulting in low maintenance & easy accessibility.
- Compact touch screen offers a simplified easy-to-follow operator interface for quick set-up and rapid product changeover, making operation easy.

Results of high-quality slicing of elongated products



Dry wide sticks



Dry extruded thin slices

Centrifugal shredder

Centris
400



High capacity centrifugal shredder, designed for consistent cut quality with maximum flexibility

- Perfect shredding and slicing of a wide range of round products such as sweet potatoes, cabbage, ... and elongated products at full length or pre-cut to determine the length of the shred.
- Robust, direct-driven power train: available with a 4 kW (5 HP) motor.
- Quickly interchangeable cutting heads offer flexibility in all cuts and shapes, such as flat, crinkle cut and V-shaped slices and shreds on a variety of vegetables.
- Trapped-key interlock safety system guarantees optimal protection of the operator.
- Can be integrated in a processing line or used as a stand-alone machine. Different executions of infeed and outlet chutes are available.



Dried meat shreds



State-of-the-art cutting solutions for petfood

Support to build your business on

PRODUCT TESTING TEST BEFORE YOU INVEST

Before you invest, take advantage of our **demonstration equipment** and our **expert advice** to identify the ideal cutting equipment for the results you want. We deliver cut product samples, together with detailed test **summary reports**, pictures, video footage and recommendations.

PRODUCT DEVELOPMENT SHARING OUR KNOWLEDGE

We encourage you to use our resources to develop your food products. Our **fully equipped test centers around the world** are available to let you evaluate product quality and appearance. This is just one way to help you test or create new products or refine existing ones.



OUR PRIORITY KEEPING YOUR MACHINE RUNNING

At FAM STUMABO our **customer care support team** guarantees rapid, premium support for your business whenever necessary. In order to maximise your running time, we offer **service support** ranging from troubleshooting to engineering and application assistance. In addition, we **stock a large inventory of commonly sold parts** and provide sharpening equipment and services for your blades.

GUARANTEED PRODUCTIVITY, SAFETY AND LONG-LASTING CUTTING EQUIPMENT

High-volume production requires solid **maintenance programmes**. FAM STUMABO offers several packages for **preventative maintenance**. Our in-depth **training programmes** are perfect for improving operator knowledge and the overall effectiveness of your installation.

Please contact us for any application you would like to discuss.



T. +32 3 450 92 20
E: sales@fam.be
www.fam-stumabo.com

