



Support to build your business on

PRODUCT TESTING TEST BEFORE YOU INVEST

Before you invest, take advantage of our **demonstration equipment** and our **expert advice** to identify the ideal cutting equipment for the results you want. We deliver cut product samples, together with detailed test **summary reports**, pictures, video footage and recommendations.



PRODUCT DEVELOPMENT SHARING OUR KNOWLEDGE

We encourage you to use our resources to develop your food products. Our **fully equipped test centers around the world** are available to let you evaluate product quality and appearance. This is just one way to help you test or create new products or refine existing ones.

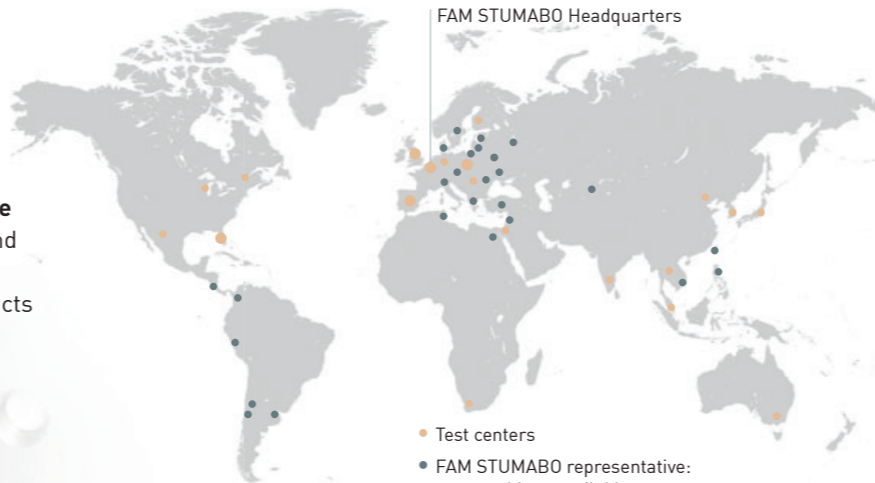

FAM STUMABO Headquarters

- Test centers
- FAM STUMABO representative: test machines available

OUR PRIORITY KEEPING YOUR MACHINE RUNNING

At FAM STUMABO our **customer care support team** guarantees rapid, premium support for your business whenever necessary. In order to maximise your running time, we offer **service support** ranging from troubleshooting to engineering and application assistance. In addition, we **stock a large inventory of commonly sold parts** and provide sharpening equipment and services for your blades.



GUARANTEED PRODUCTIVITY, SAFETY AND LONG-LASTING CUTTING EQUIPMENT

High-volume production requires solid **maintenance programmes**. FAM STUMABO offers several packages for **preventative maintenance**. Our in-depth **training programmes** are perfect for improving operator knowledge and the overall effectiveness of your installation.

Please contact us for any application you would like to discuss.



© FAM nv - SEGMENT_POULTRY_EN_0526



T. +32 3 450 92 20 | E: sales@fam.be | www.fam-stumabo.com



ROBUST HIGH-TECH SANITARY EQUIPMENT

For precision cutting of poultry and plant-based alternatives

Your perfect partner for precision cutting of cooked and frozen poultry applications

FAM STUMABO designs and supplies cutting solutions for a multitude of food applications with over 40 years of experience combined with a global presence. Over the years, we have built up strong partnerships with leading meat processors worldwide. Our mechanical cutting solutions are known for their precise cut quality, hygienic design, maximized yield at high capacity and operator friendliness. At **FAM STUMABO** you will find an experienced and innovative partner with an **open-minded approach**. We develop cutting equipment designed to meet the demands of today's most **versatile and high-capacity** poultry processing operations, such as a focus on **top sanitary design** to meet the highest globally recognised standards. Our cutting technology assures peak production of **high-quality products with the highest level of efficiency at high speed** and is designed to dice, strip cut, shred or hot cooked, frozen or raw poultry to a **wide range of sizes**.

"Together we cut your product to perfection!"

INNOVATIVE SOLUTIONS FOR POULTRY REPLACERS

FAM STUMABO has developed innovative cutting solutions that **help alternative protein processors** produce top quality poultry-like alternatives.

We always work together with you to understand the challenges you face when it comes to cutting **plant-based, alternative poultry products**.

The collaboration can take different forms, from testing on-site at your premises to performing tests in our own labs.



GREAT FLEXIBILITY

We understand the flexibility needed in the very diverse poultry cutting industry. **FAM STUMABO** offers a very wide range of machines capable of **cutting poultry in different conditions**

- e.g.
- roasted
 - baked
 - grilled
 - fire roasted
 - smoked
 - deep fried
 - raw-cooked
 - tumbled
 - injected



Versatile belt dicer

Yuran Hytec 300



Increased feeding capacity and unrivalled cutting versatility

- Belt-fed dicer designed to dice, strip-cut and shred a large variety of meat and alternative protein products.
- Compared to the standard model Yuran Hytec 240, the 300 mm wide feed belt offers an increased capacity and the ability to process products with larger dimensions.
- Multi-product cutting versatility due to the use of dual independent variable speed motors. Dice, strips, pulled look shreds, chunks can be produced from products of a pre-determined or natural thickness.
- Specialized cutting tools, designed to cope with the unique characteristics of extruded products to create alternative meat products in cuts and shapes familiar to animal-based meat.
- Dual independent variable speed motors allow cut size/shape adjustments without the extra expense of additional cutting tools.
- Quick removable splined shafts of the cutting spindles provide fast changeovers from one cut size to another reducing downtime in the production process.
- Smart hygienic design ensures that the machine can be cleaned quickly, easily and safely.

Guillotine slicer/dicer

GD500



Designed to slice and dice while maintaining optimal product appearance and a minimum of slivering and fines

- Cutting of fragile and fibrous poultry products with perfect cut quality and a minimum of slivering and fines.
- Guillotine cutting principle does not accelerate or crush the product during the cutting action, greatly improving yield and reducing fines. Suited to cut hot cooked chicken and thigh meat.
- Very solid machine for continuous production in a fully integrated line.
- Covers and cutting head are quickly dismantled for cleaning.
- All stainless steel or USDA/FDA approved polymeric materials in food contact areas.



Cooked chicken dice

Precise V-belt slicer

Volantis



V-belt slicer designed for the precision transverse slicing of filets

- Precise cutting of filets up to a diameter of 115 mm (4,5").
- Two-meter-long V-belt will perfectly align the product towards the slicing wheel and bring it up to the required speed before cutting.
- Transversal cutting principle allows precise high-speed slicing while maintaining an excellent slicing quality.
- Highly efficient machine design resulting in low maintenance & easy accessibility.
- Compact touch screen offers a simplified easy-to-follow operator interface for quick set-up and rapid product changeover, making operation easy.

Results of high-quality slicing



Flavoured chicken slices



Cooked chicken slices

PRODUCE KNOWLEDGE

Apart from an innovative line of solutions, what sets the bar high for FAM STUMABO is a **highly qualified team of experts** that knows the needs of customers inside and out.

Our team of application specialists always looks to understand more about the parameters that affect the cutting (of any product), such as the **temperature, size, texture, and the condition** of the product.

Only then can we select the best cutting solution, delivering the greatest value and best result for the customer.

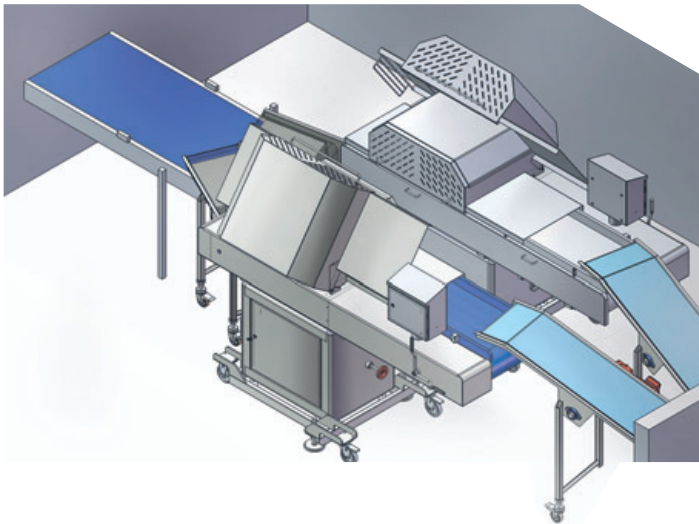

PRODUCTION PROCESS KNOWLEDGE

FAM STUMABO designs machines, blades and cutting tools that respond to your unique processing needs. Tailored not just to your current production line, but to offer that added flexibility. This allows you to **easily integrate our machinery** into any full line with quick and effortless switching of the cutting equipment. We **offer infeed systems appropriate for specific applications** on our machines.

Two GD500 machines in a line for hot cooked chicken, using a double infeed conveyor and wire belt outfeed.

MACHINE DESIGN KNOWLEDGE

All **blades** are **manufactured in-house** and made from the best food grade stainless steel materials.

Our expertise helps to select the right blade for the application.

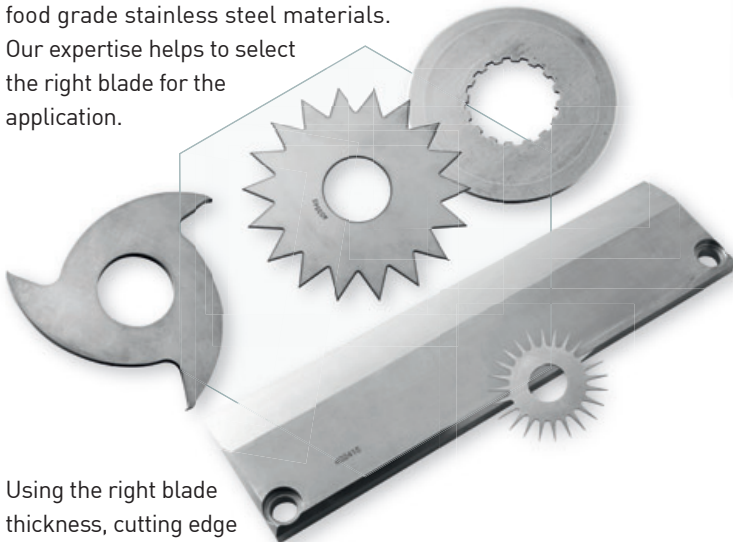

Using the right blade thickness, cutting edge grind, edge profile and strength is critical for the best cutting process with minimum waste.

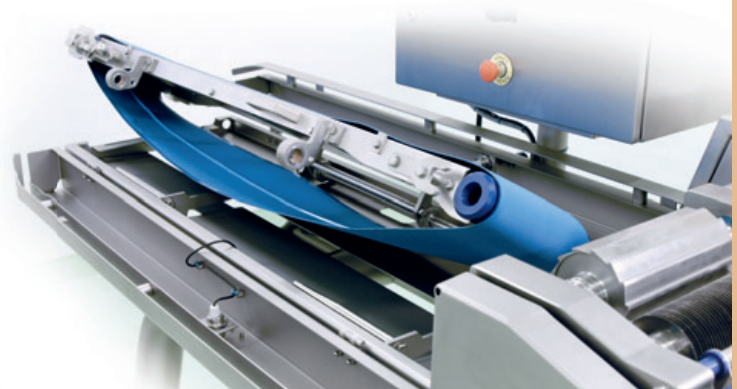

Hygienic focus: All equipment is designed to permit fast, yet thorough cleaning.

Our machines are designed for flexible and effortless operation with a special focus on ensuring the **safety of operators and maintenance personnel at every risk level**. The design of our machines and cutting tools assures long service life under all conditions with a minimum of maintenance costs and downtime through **simplified, yet rugged construction**. Standardisation of the cutting tools and knives helps to avoid human errors.

Machines for high-qu

State-of-the-art
cutting solutions
for fresh,
cooked and
frozen poultry

Hymaks



Uncompromising sanitary design for high-capacity outputs

- Robust, highest capacity large drum dicer with a unique and uncompromising sanitary design.
- Striking power potential of 20,5 kW (27,5 HP) with two synchronised motors with variable frequency drives. One of 5,5 kW (7,5 HP) for the cutting tools and one of 15 kW (20 HP) for the impeller.
- Highly uniform dicing and strip cutting of cooked and tempered frozen poultry products with a minimum of waste.
- Machine operation by means of touch screen.

"FAM STUMABO has the know-how to offer the best-fit cutting solution for any type of product we'd like to cut. (whether it's cooked/steamed/tumbled/roasted/...) Their broad machine range helps us to align our products with recent market advances and keep up with the latest food trends."

Major European cooked poultry processor

Quality dicing and strip-cutting

CMD₂



Continuous operation for high capacities

- Robust, high-capacity drum dicer for uniform dicing and precise strip cutting.
- Powerful 11 kW (15 HP) motor with variable-frequency drive can handle extreme conditions.
- Ability to cut at very low temperatures between 2° C and -10° C (35,6° F and 14° F), depending on texture, fat, moisture and salt content. Resulting in a non-sticky, free rolling product, simplifying the weighing and packaging.
- Superior, attractive cut quality as the product is not forced through a cutting grid but gently cut with rotating knife spindles.
- Removable splined shafts that make it quick and easy to switch cutting tools.

Results of high-quality dicing and strip-cutting



Cooked chicken strips



Raw chicken dice

Flexifam₂



Designed for flexible and effortless operation

- Medium high-capacity dicing and strip-cutting for cooked and tempered-frozen poultry products.
- 5,5 kW (7 HP) motor with optional variable frequency drive
- Produces very clean dice and strips in sizes ranging from very small to medium.
- Unique disassembly and reassembly system for the cutting spindles enables fast changeover from one cut size to another in just minutes.
- The hinged infeed and discharge chute facilitates access to the machine and enables thorough cleaning.
- The hinged control cabinet provides quick access to the drive compartment for maintenance and repair interventions.



Cooked chicken dice

Accurate belt cutter

Yuron
Hytec 240



Results of high-quality dicing, strip-cutting and pulled look



Pulled look on chicken (fine)



Pulled look on chicken (rough)



Quorn dice



Chunks of extruded product

Belt cutter, designed for dicing and strip-cutting at high capacities

- Specialized in cutting frozen/tempered or chilled, and hot cooked poultry in dice and shreds, or pulled look-alike products.
- Cutting principle incorporating a feed roll that flattens the filets and provides a positive transfer towards the cutting spindles, cutting the product in strips or dice. The thickness of the strips or dice will be the thickness of the original product.
- Quick changeover from one cut size to another due to the use of fast removable cutting spindle shafts.
- Drive zone and product zone of the machine are completely separated allowing quick and thorough cleaning.
- Hygienic 240 mm (9,4") wide belt with guide strip and belt edge sealing.
- Quick removal of conveyor belt enables thorough cleaning.
- Dedicated tools for cutting plant-based, alternative poultry-like products.