



FAM

INDUSTRIAL FOOD CUTTING SOLUTIONS



stumabo



ROBUST HIGH-TECH SANITARY EQUIPMENT

For precision cutting of meat and
alternative proteins

Your perfect partner for precision cutting of cooked and frozen meat applications

FAM Stumabo designs and supplies cutting solutions for a multitude of food applications with over 40 years of experience combined with a global presence. Over the years, we have built up strong partnerships with leading meat processors worldwide. Our mechanical cutting solutions are known for their precise cut quality, hygienic design, maximized yield at high capacity and operator friendliness.

At FAM Stumabo you will find an experienced and innovative partner with an **open-minded approach**. We develop cutting equipment designed to meet the demands of today's most **versatile and high-capacity** meat cutting operations, such as a focus on **top sanitary design** to meet the highest globally recognised standards.

Our cutting technology assures peak production of **high-quality products with the highest level of efficiency at high speed** and is designed to dice, strip cut or shred frozen, chilled or hot cooked meat to a **wide range of sizes**.

"Together we cut your product to perfection!"

INNOVATIVE SOLUTIONS FOR MEAT REPLACERS



FAM Stumabo has developed innovative cutting solutions that **help alternative protein processors** produce top quality meat-like alternatives.

We always work together with you to understand the challenges you face when it comes to cutting **alternative meat products**.

The collaboration can take different forms, from testing on-site at your premises to performing tests in our own labs.



GREAT FLEXIBILITY

We understand the flexibility needed in the very diverse meat cutting industry. FAM designs its machines to empower customers with the ability to make multiple products with one machine.

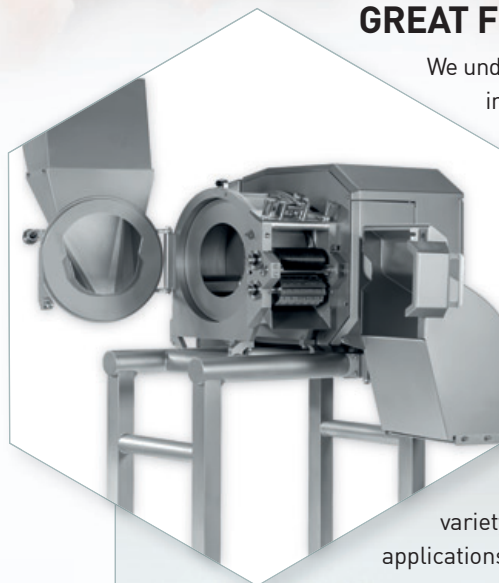

Example: CMD.2

Very versatile dicer designed to uniformly strip-cut and dice a wide variety of cooked & frozen meat applications.



PRODUCE KNOWLEDGE

Apart from an innovative line of solutions, what sets the bar high for FAM Stumabo is a **highly qualified team of experts** that knows the needs of customers inside and out.

Our team of application specialists always looks to understand more about the parameters that affect the cutting (of any product), such as the **shape, temperature, product size, texture, moisture, salt, fat content and the condition** of the product.

Only then can we select the best cutting solution, delivering the greatest value and best result for the customer.

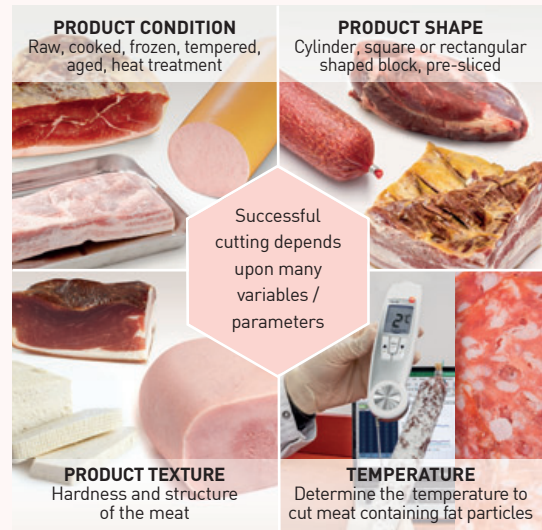
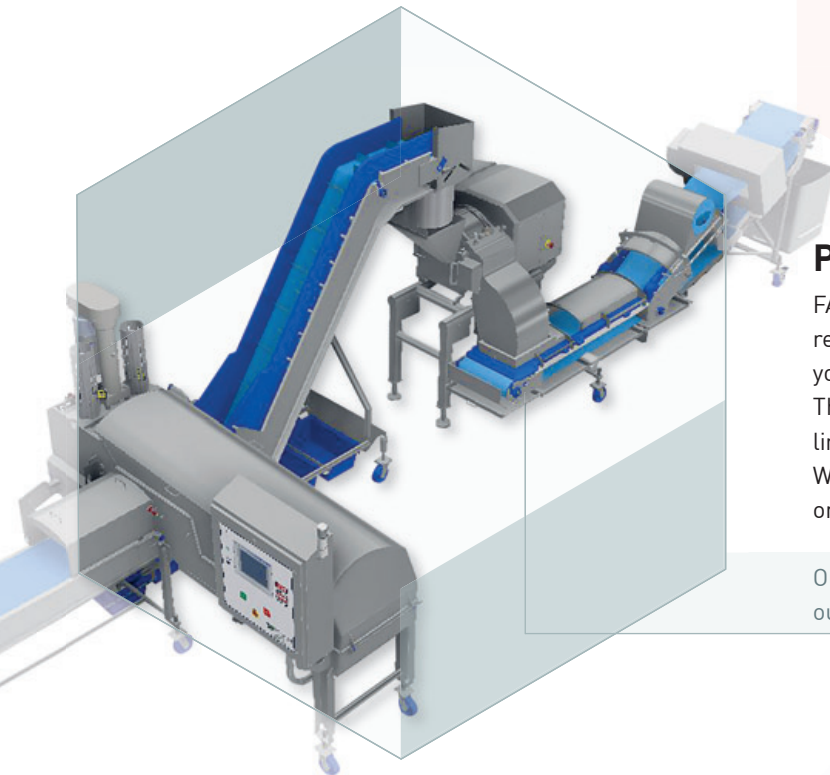

PRODUCTION PROCESS KNOWLEDGE

FAM Stumabo designs machines, blades and cutting tools that respond to your unique processing needs. Tailored not just to your current production line, but to offer that added flexibility. This allows you to **easily integrate our machinery** into any full line with quick and effortless switching of the cutting equipment. We **offer infeed systems appropriate for specific applications** on our machines.

Our CMD.2 in a protein line with pre-cuber, infeed and outlet conveyor.

MACHINE DESIGN KNOWLEDGE

All **blades** are **manufactured in-house** and made from the best food grade stainless steel materials.

Our expertise helps to select the right blade for the application.

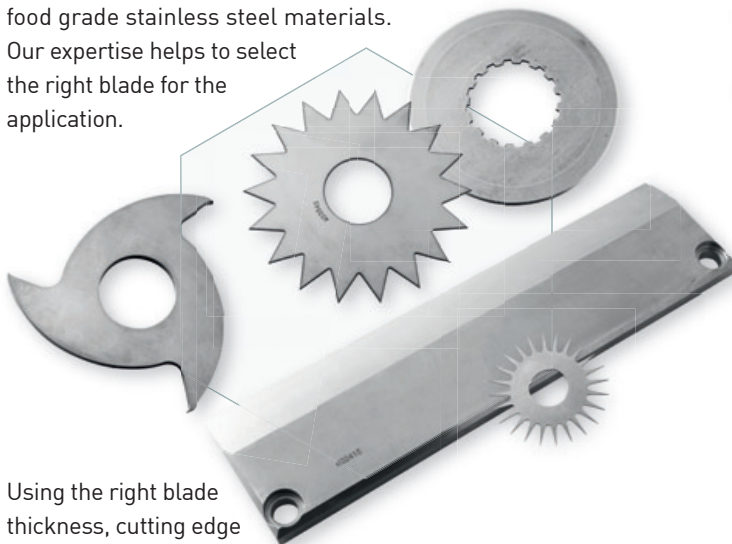

Using the right blade thickness, cutting edge grind, edge profile and strength is critical for the best cutting process with minimum waste.



Hygienic focus: All equipment is designed to permit fast, yet thorough cleaning.

Our machines are designed for flexible and effortless operation with a special focus on ensuring the **safety of operators and maintenance personnel at every risk level**. The design of our machines and cutting tools assures long service life under all conditions with a minimum of maintenance costs and downtime through **simplified, yet rugged construction**. Standardisation of the cutting tools and knives helps to avoid human errors.

Machines for high-qu

State-of-the-art
cutting solutions
for cooked and
frozen meat

Hymaks



Uncompromising sanitary design for high-capacity outputs

- Robust, highest capacity large drum dicer with a unique and uncompromising sanitary design.
- Striking power potential of 20,5 kW (27,5 HP) with two synchronised motors with variable frequency drives. One of 5,5 kW (7,5 HP) for the cutting tools and one of 15 kW (20 HP) for the impeller.
- Highly uniform dicing and strip-cutting of cooked and tempered-frozen meat products with a minimum of waste.
- Machine operation by means of touch screen.

Results of high-quality dicing



Black Forest ham dices



Serrano ham dices

"With the CMD.2 we have a powerful, robust and reliable machine in house, which guarantees us continuous high quality cutting of frozen products."

Family Butchers - Germany
Sausage and ham processor

Quality strip-cutting and dicing

CMD₂



Continuous operation for high capacities

- Robust, high-capacity drum dicer capable of uniform cutting of frozen pork and beef in very clean dices and strips.
- Powerful 11 kW (15 HP) motor with variable frequency drive can handle extreme conditions.
- Ability to cut at very low temperatures between 2 °C and -15 °C (35,6 °F and 5 °F), depending on texture, fat, moisture and salt content. Resulting in a non-sticky, free rolling product, simplifying the weighing and packaging.
- Superior, attractive cut quality as the product is not forced through a cutting grid but gently cut with rotating knife spindles.
- Removable splined shafts that make it quick and easy to switch cutting tools.



Tempeh dices



Cooked ham dices

Flexifam 55

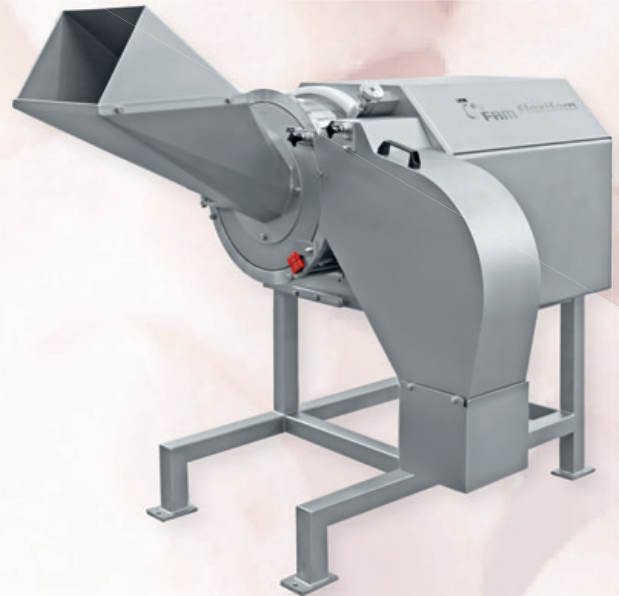

Designed for flexible and effortless operation

- Medium high-capacity dicing and strip-cutting for cooked and tempered-frozen meat products.
- 5,5 kW (7 HP) motor with optional variable frequency drive
- Produces very clean dices and shreds in sizes ranging from very small to medium.
- Cutting tools are quick and easy to change, reducing downtime.

"Our quality products ask for professional and reliable equipment. The CMD.2 has a striking power potential, allowing us to continuously cut our frozen Serrano hams in the most sanitary way."

Carnicas Serrano - Spain

Producer of Spanish Serrano ham



Accurate belt cutter

Yuron
Hytec



Results of high-quality dices, strips and pulled look



Pulled look pork



Ham strips



Bacon strips



Tofu strips

Belt cutter, designed for dicing and strip-cutting at high capacities

- Specialized in cutting frozen/tempered or chilled, and hot cooked meat in dices and strips, or pulled look-alike products.
- Cutting principle incorporating a feed roll that flattens the product and provides a positive transfer towards the cutting spindles, cutting the product in strips or dices.
- Machine accepts incompressible products up to 27 mm (1/16"). The thickness of the strips or dices will be the thickness of the original product.
- Also suitable for larger diameter products to create a hand-pulled look.
- Quick changeover from one cut size to another due to the use of fast removable cutting spindle shafts.
- Drive zone and product zone of the machine are completely separated allowing quick and thorough cleaning.
- Hygienic 240 mm (9,4") wide belt with guide strip and belt edge sealing.
- Quick removal of conveyor belt enables thorough cleaning.
- Dedicated tools for cutting alternative meat-like products.

"The Yuron Hytec has been a versatile and effective machine with a high value output. It's easy to use and maintain."

Planterra Foods - USA

Plant-based division of JBS Foods

Innovative shredder

Centris 400C



High-capacity innovative shredder, designed for consistent cut quality with maximum flexibility

- Can handle a wide range of cut sizes like V-cut shreds (1,80 mm - 0,07" / 2,50 mm - 0,097" / 3,20 mm - 0,125"), strips and slices on all kinds of meat products.
- Cutting heads can be changed – for different cuts of different meat types – in just minutes.
- 7,5 kW (10 HP) stainless steel motor and planetary gearbox. The large infeed provides uniform product flow to the 16-blade cutting head.
- Trapped-key interlock safety system guarantees optimal protection of the operator.

Result of high-quality shredding



Prosciutto shreds

Precise V-belt slicer

Volantis™



V-belt slicer designed for precision transverse slicing of a wide variety of elongated products

- Precise cutting of elongated products from 25 mm (1") up to a diameter of 60 mm (2 3/8") such as sausages, salami, ...
- Perfect product enclosure and guidance towards the cutting tools by means of the driven top belt.
- Two-meter-long V-belt will perfectly align the product towards the slicing wheel and bring it up to the required speed before cutting.
- Product is sliced without waste or end pieces.
- Transversal cutting principle allows precise high-speed slicing while maintaining an excellent slicing quality.
- Highly efficient machine design resulting in low maintenance & easy accessibility.
- Compact touch screen offers a simplified easy-to-follow operator interface for quick set-up and rapid product changeover, making operation easy.

Results of high-quality slicing of elongated products



Chorizo slices



Pork sausage slices

Support to build your business on

PRODUCT TESTING TEST BEFORE YOU INVEST

Before you invest, take advantage of our **demonstration equipment** and our **expert advice** to identify the ideal cutting equipment for the results you want. We deliver cut product samples, together with detailed test **summary reports**, pictures, video footage and recommendations.



PRODUCT DEVELOPMENT SHARING OUR KNOWLEDGE

We encourage you to use our resources to develop your food products. Our **fully equipped test centers around the world** are available to let you evaluate product quality and appearance. This is just one way to help you test or create new products or refine existing ones.

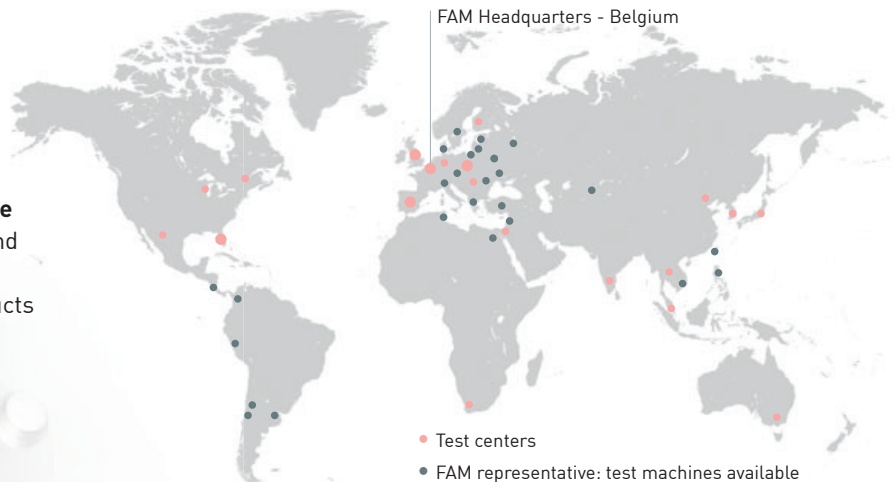

OUR PRIORITY KEEPING YOUR MACHINE RUNNING

At FAM Stumabo our **customer care support team** guarantees rapid, premium support for your business whenever necessary. In order to maximise your running time, we offer **service support** ranging from troubleshooting to engineering and application assistance. In addition, we **stock a large inventory of commonly sold parts** and provide sharpening equipment and services for your blades.



GUARANTEED PRODUCTIVITY, SAFETY AND LONG-LASTING CUTTING EQUIPMENT

High-volume production requires solid **maintenance programmes**. FAM Stumabo offers several packages for **preventative maintenance**. Our in-depth **training programmes** are perfect for improving operator knowledge and the overall effectiveness of your installation.

Please contact us for any application you would like to discuss.

